



S1000XR 2020-2021

FITTING INSTRUCTIONS

TO BE FITTED BY A QUALIFIED TECHNICIAN



THIS SHEET INCLUDES FITTING INSTRUCTIONS FOR THE FOLLOWING PARTS:

Secondary Alternator Cover Part No. EC-S1000XR-2020-1-GBR / Secondary Clutch Cover Part No. EC-S1000RR-2019-2-GBR / Secondary Pulse Cover Part No. EC-S1000RR-2019-3-GBR / Secondary Water Pump Cover Part No. EC-S1000RR-2019-5-GBR / Paddock Stand Bobbin Set Part No. BA12-8-GBR-SET



SECONDARY ALTERNATOR COVER – PART NO. EC-S1000XR-2020-1-GBR

- 1 Remove 4 existing stretch bolts from the stock Alternator cover, shown as position Bolt 1, 2, 3 & 4.
- 2 Place the Secondary Alternator Cover over the stock cover.
- 3 Assemble 4 replacement stainless steel M6X40A2 TORX bolts loosely in the correct position as shown.
- 4 Tighten bolts to a Torque of 10Nm. DO NOT OVERTIGHTEN.

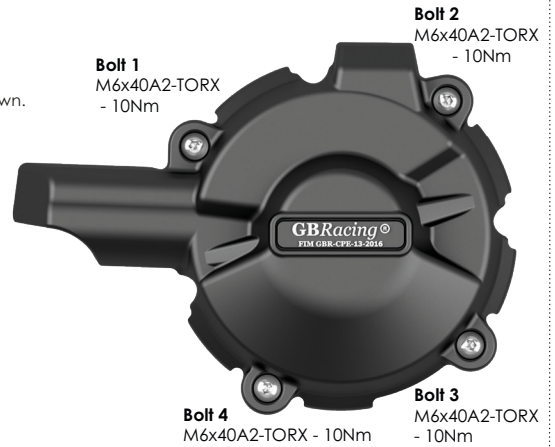
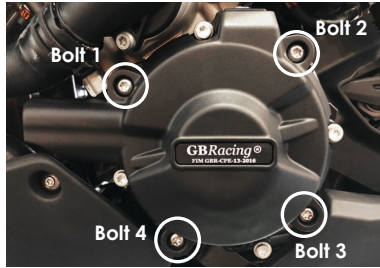
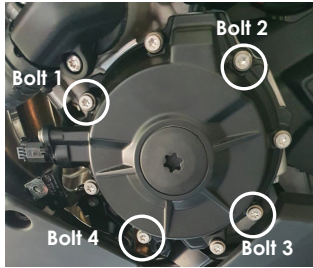

SECONDARY CLUTCH COVER – PART NO. EC-S1000RR-2019-2-GBR

- 1 Remove 4 existing bolts from the stock clutch cover, shown as position Bolt 1, 2, 3 & 4.
- 2 Place the Secondary Clutch Cover over the stock cover.
- 3 Assemble 4 replacement M6X40A2 TORX bolts, loosely in the correct position as shown.
- 4 Tighten bolts to a Torque of 10Nm. DO NOT OVERTIGHTEN.

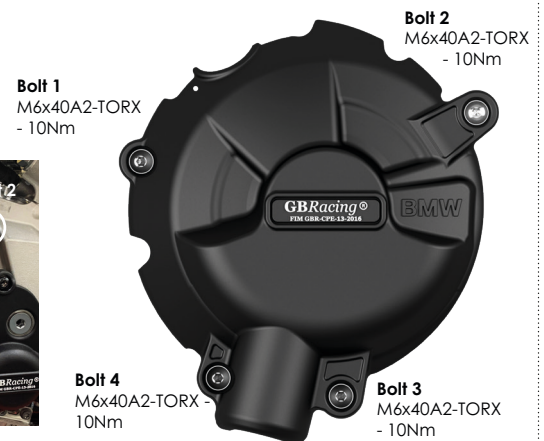
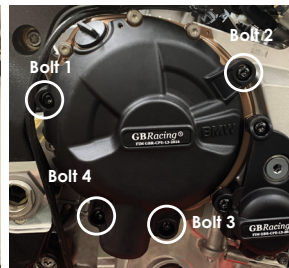
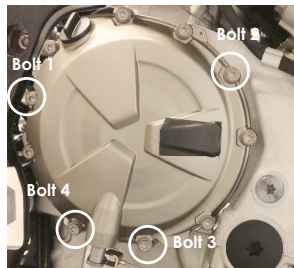

SECONDARY PULSE COVER – PART NO. EC-S1000RR-2019-3-GBR

- 1 Remove 3 existing bolts indicated in Fig 1.
- 2 Fit GBRacing fixing bracket to existing bracket as shown in Fig 2.
- 3 Fixing bracket is fitted to engine using existing clutch cable mount.
- 4 Place the Secondary Pulse Cover over these bolt positions in Fig 1.
- 5 Assemble 2 replacement M6X40A2 TORX bolts, loosely in the correct position as shown at bolt positions 1 & 3.
- 6 Bolt 2 M6X30A2 TORX will secure to the fixing bracket as indicated in Fig 2 & 3.
- 7 Tighten bolts to a Torque of 10Nm. DO NOT OVERTIGHTEN.

Fig 1.

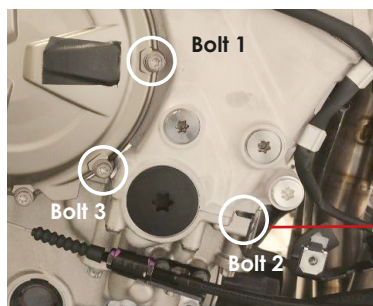

Fig 3.

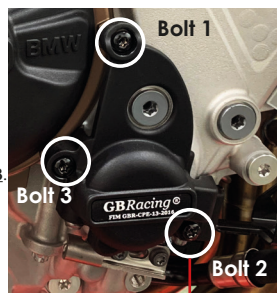
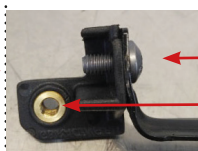
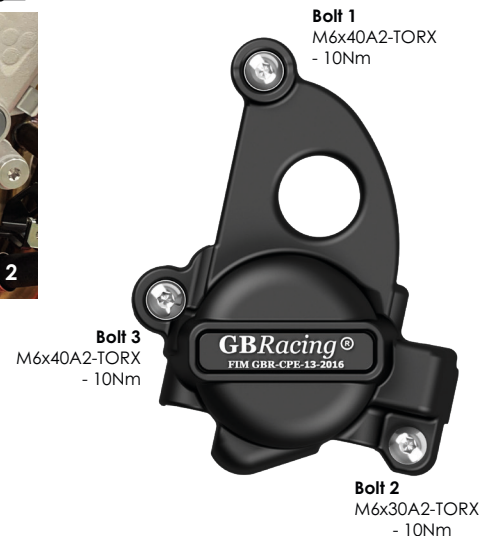

Fig 2.
Fixing Bracket (EC-S1000RR-2019-3-FB-GBR) for Bolt 2



Use OE mounting bolt here
Bolt 2 M6X30A2 mounting point



ENGINE COVER SET: EC-S1000XR-2020-SET-GBR:

EC-S1000XR-2020-1-GBR, EC-S1000RR-2019-2-GBR, EC-S1000RR-2019-3-GBR, EC-S1000RR-2019-3-FB-GBR, EC-S1000RR-2019-5-GBR



S1000XR 2020-2021

FITTING INSTRUCTIONS

TO BE FITTED BY A QUALIFIED TECHNICIAN



SECONDARY WATER PUMP COVER PART NO. EC-S1000RR-2019-5-GBR

- 1 Fitting requires a COLD engine.
- 2 Decompress the system before loosening existing stock bolts.
- 3 Have all 3 Replacement Bolts to hand before removing existing stock bolts.
- 4 Loosen bottom fairing bolt to enable access to the Water Pump.
- 5 Remove 3 existing bolts from the stock water pump cover shown as bolt positions 1, 2 & 3
- 6 Place the Secondary Water Pump Cover over the stock cover.
- 7 Assemble 3 replacement bolts, loosely in the correct position as shown.
- 8 Tighten bolts to a Torque of 10Nm.
DO NOT OVERTIGHTEN.
- 9 Tighten bottom fairing bolt.
- 10 Check coolant level & top up if necessary before starting engine.

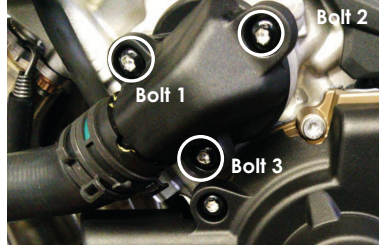

Bolt 1
M6X30A2-TORX
- 10Nm

Bolt 2
M6X30A2-TORX
- 10Nm

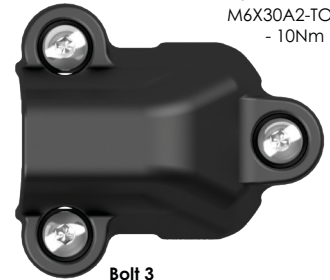

Bolt 3
M6X30A2-TORX
- 10Nm

PADDOCK STAND / BOBBIN SET – PART NO. BA12-8-GBR-SET

- 1 Assemble M8 x 40mm Bolt through the moulded bobbin.
- 2 Tighten bolts to swing arm boss, 8 Nm.
DO NOT OVERTIGHTEN

1 x M8 x 40 Bolt



1 x Moulded Paddock Stand / Bobbin